



IET 499 Industrial Projects Capstone

A PROJECT REPORT
PREPARED IN PARTIAL FULFILLMENT OF THE
REQUIREMENT FOR THE DEGREE OF
BACHELOR OF SCIENCE
IN
ENGINEERING TECHNOLOGY

THOR'S HAMMER
Final Report

Nathaniel Klebe
Darren Heath
Michael Falco
Trey Case
Shaheed al Jaffar
Carlie Root

Advisor: Soo-yen Lee

Spring Semester, 2021

Ethics Statement and Signatures

A team consisting of the individuals listed below solely prepared the work submitted in this report and it is original. Excerpts from others' work have been clearly identified, their work acknowledged within the text and listed in the list of references. All of the engineering drawings, computer programs, formulations, design work, prototype development and testing reported in this document are also original and prepared by the same team of students.



Nathaniel Klebe



Darren Heath



Michael Falco



Trey Case



Shaheed al Jaffar



Carlie Root

Soo-yeon Lee

TABLE OF CONTENTS

Chapter	Page
Cover Page	
Ethics Statement and Signatures	2
Table of Contents	3
Abstract	4
1. Introduction	5
• Project Description	5
• Overview	5
• Relevant history and background	5
• Stakeholders	5
• Primary and Secondary Customers	5
• Assumptions and Constraints	5
• Customer Needs	5
2. Project Formulation	6
• Design Target Specifications	6
• Survey of Related Standards and Codes	7
• Impact of Design in a Global and Societal Context	7
• Environmental Impact and Sustainability	8
• Health and Safety (Fabrication and Utilization)	8
3. Project Management	9
• Overview	9
• Breakdown of Work into Specific Tasks	9
• Organization of Work and Timeline	11
• Design Concept 1	13
• Design Concept 2	13
• Design Concept 3	14
• Concept Selection on Target Specifications	16
• Breakdown of Responsibilities Among Team Members	15
• Concept Selection on Customer Needs	16
• Proposed Design	17
• Initial Cost Model	18
• Bill of Material	18
• Design Consideration	
• Assembly and Disassembly	18
• Manufacturability	18
• Maintenance of the system	19

4. Engineering Design and Analysis	20
• Force Analysis	20
• Stress Analysis	21
• Design Based on Static and Fatigue Failure Design Theories	21
• Dynamic/Vibration Analysis of the System	22
• Material Selection	22
• Finite Element Analysis	22
• Design Overview	23
• Procedures, testing, etc	23
• Testing and Evaluation	23
• Test Results and Data	23
5. Conclusion	24
• Lessons Learned/Improvements	24
• Evaluation of Project Success	24
• Sponsor Feedback	24
• Areas for Future Research	24
6. References	26
Appendix A. Detailed Engineering Drawings of the Part	28
Appendix B. Rendering of Final Design	29
Appendix C. Bill of Materials	30
Appendix D. Final Cost Model	31
Appendix E. Project Photo Album	32

Abstract

Central Michigan University teamed up with Bay Cast to create a functional metal casting Thor's Hammer. The team will be submitting a hammer that includes the shaft and the hammerhead that is connected, as well as a report and video describing the process they went with to get the final hammer design. This will include the standards that were used to help with the deciding step for the material, design, and manufacturing process. As well as the methods that were used to cast CMU's Thor's hammer and the methods to attach the hammerhead to the shaft. This will then all be submitted to the Cast in Steel competition where it will be judged and viewed for all other schools to see.

Chapter 1. Introduction

The Cast in Steel competition that is sponsored by the Steel Founders Society Foundation, states for each team to produce a functional one-handed Thor's hammer using modern casting tools and designs. Be able to utilize casting to its fullest extent with the best quality, unique features and close to size with the initial CAD design. The purpose of this competition is to get more people involved in the foundry industry and try to get more people interested in the topic of casting. For the competition, the CMU team partnered with the steel casting company Bay Cast, which is located out of Bay City in Michigan. When touring the facility they had two main buildings, one for casting and melting while the other for machining. The team focused more on the casting building where the molds were made. When touring the facility, the Bay Cast team presented and described all the machines that could possibly be used to complete Thor's hammer. Bay Cast was able to lend the CMU team all the necessary parts and machinery to melt our alloy steel. Being a well known founder industry, they were also able to help in the process of the sand molding and supervised the process. Some of the limitations that the team dealt with was after the casting process. When looking at their machine shop at Bay Cast, the machines they had were mostly used for larger parts rather than small hammerheads. With that, the CMU group had to machine in-house using a Haas NGC (Next Generation Controller) CNC mill machine with three axes that can tackle smaller parts like the hammerhead.

Chapter 2. Project Formulation

In the casting process, there are a lot of different components that can justify the decision making of what casting process to choose and what material to choose, and why. In the competition, the CMU team is asked to utilize the casting process and all the different casting styles when dealing with foundry work. One of the first decisions the team makes is the choice of steel being used for the hammer.

In communication with Bay Cast, they gave the team a list of different steels that they are able to forge at their facility. More specifically, two different options for steel that would possess properties aligned with a typical hammerhead or striking part including 8600 series steel and 4300 series steel. Both steels have high strength levels with a high yield strength because of the high carbon count. Depending on the amount of carbon in the steel, the more carbon in the steel increases the strength but it will decrease the toughness and the weldability of the steel. After looking at the yield strength of both series of steel, the 8600 series has a higher yield strength which is the amount of force that can be applied before the metal breaks (International ASTM, 2013). Other properties that affect the material to pick are also the toughness, hardness, and oxidation resistance.

When talking to Bay Cast, the major casting style they use is sand casting. Bay Cast uses sand casting as it's a quicker and cheaper method when dealing with medium to large pieces, but is limited to design methods when dealing with the pattern of smaller parts (Glownia, 2017). In order to fulfill all casting needs, certain properties need to be considered when going about sand casting. This deals with the fluid life and fluid flow of 8630 low-alloy steel, solidification rate, and rigging system which is done by a casting process simulation on a computer program that is provided by Bay Cast (International A.S.M, 2009). For 8630 low-alloy steel, the fluid life and

flow focus on the state of molten steel and looks at the viscosity and is based on the temperature of steel. For standard forging temperature to give the best flow rate, steel needs to be heated up between 1700 ~ 2200 °F (Steel grading, 2021). The higher the temperature the alloy steel is, the better flow of steel through the mold becomes which in return gives a better outcome of a whole part (International A.S.M, 2009). When the pour is complete the metal will then start the solidification process for 8630 Steel (Steel grade, 2021). When the metal is poured into the mold, the molten metal applies a force inside the mold. In order to prevent the cope and drag flask from separating, clamps are needed to hold the cope and drag in place so no pour overs happen during the pouring process. Force is calculated with the area of all the cavities and runners (the area that the molten metal will be filling) multiplied by the yield strength of the alloy steel divided by 1000 gives the amount of clamping force needed in order for the melted steel to stay inside the mold (Galles, 2017).

When the steel is poured into the mold there is also a heat transfer consideration with the steel and the mold during the cooling process of the steel. Lakesand has a poor specific heat capacity which can cause the surface of the molten metal that touches the sand to cool at a much faster rate (Wang & Mangharan, 2018). A material of chromite was suggested by Bay Cast. Chromite is great with high temperature metals for it has a low thermal expansion rate that helps keep the mold in place, and also helps with surface finishes (Bussoledi, 2020). It is also a metallic powder material with a very fine grain fineness which helps with bonding when exposed to heat (Hoyt, 2006).

A key factor to help keep the mold from crumbling is finding the best mixture of sand to the two-part resin mixture to the best quality of the mold without having too much water in the sand which can cause cold spots and create defects in the steel. The lakesand is mixed with resin

and corented which is a two part resin mixture with the lakesand. The amount of resin and corented used in the process is calculated by taking the weight of the lake sand and times 1.45% will give you the amount of resin being used in the mixture. From there the corented is measured by taking the weight of resin used and times 30% to the weight of resin to give the amount of corented being used (International ASTM, 2013).

After understanding the properties of the alloy steel, there is also a factor of power used when melting the steel. During the time the furnaces are on an abundant amount of power is needed to be able to get the coreless induction furnace to high temperatures needed to melt the steel. Just for safety purposes, Bay Cast will only melt metal during night time when everyone will be sleeping considering that is the best time when the least amount of power is needed for civilians in Bay City. There are also other safety factors that need to be addressed to show proper safety protocols when going through the process of developing a mold as well as pouring the metal.

During the casting process at Bay Cast, we used proper PPE (personal protection equipment) required by both OSHA and Bay Cast. This included ANSI Z89.1 hard hats used to protect from falling objects, gloves when handling chemicals or abrasive materials, hearing protection when needed, and ANSI Z87.1 rated safety glasses. During the Melting process, high temperature protective apparel is worn to protect from the high temperatures and possible metal flying around from the slag in the furnace.

Chapter 3. Project Management

With the properties of steel and how the fluid life, fluid flow, solidification rate, and how the elements added to the steel improve the quality of the overall properties, the actual process of what is going to be done step-by-step can be described. This will help understand everything that took place to get the casted hammer that was designed in CATIA, the primary CAD software used, to be fully casted, and at the end be a functional hammer for the Cast in Steel competition.

Starting off the process, the CMU group created the pattern to be used in the casting. After, they coated the pattern in a wash to give the sand a protection barrier. The wash was then dried and placed in a drag mold. The sand was then coated with a white powder substance to prevent the sticking of the chromite to the pattern. The team then layered a 2 inch thickness of chromite around the pattern, making sure the chromite is compacted around the pattern to prevent any loose grains of chromite from occurring. After the chromite is placed, the lakesand resin mixture is used to cake the chromite to complete the mold for the drag. A torch is then used, with temperatures up to 700 deg F, to heat up the lakesand to activate the chemical reaction of the resin mixture to harden the drag mold. The mold was then left heated for roughly an hour and a half until the sands are solid; (when the mold is hardened it is expected to be checked over for any mold errors and loose sands. This is useful for the purpose to create higher quality molds). When examining the mold, a 50 ton crane elevator is used to spectate both sides of the drag. After examination, the drag flask is then faced upwards, and four wood blocks are thereafter placed on each corner of the cope mold for leveling. White powder substance is then again covered over the patterns, runners, etc. From that, four risers and a fifth main feed riser are placed on top of the pattern in the cope and placed in an area that has a large area of the cavity where most of the molten steel will be sitting. Lake sand is then applied in the cope mold to start

forming the top part of the mold. Carefully placed layers of lake sand are compacted to help prevent any mold errors when it is heated and hardened, it took 1.25 hours for this step to be cured. When the cope mold is hardened, a thorough examination is needed to check for loose sand in the mold which can sometimes be caused by a poor mixture of resin in lake sand.

When it comes time for the molten metal to be poured into the cast, such a task is done overnight due to the excessive amount of power needed. The CMU team also worked with Bay Cast in figuring out a day that both parties can pour the 8630 steel for the hammerheads while also pouring the same 8630 steel for another customer's part. This reduced the cost to manufacture and also did not send metal to be recycled. A coreless induction furnace was used to heat up the metal as it used high and low frequencies to produce high temperatures that reach up to 2200 °F (Green, 2018). From the prep work with the furnace and also the mixture in the steel, a thermocouple is then attached to a rod that reads the temperature of the alloy steel in the ladle to make sure the temperature of the molten steel is close to around the temperature of 2200 °F. The ladle is then lifted from a 50 ton crane elevator and moved right above the Central Michigan University hammer mold. A Bay Cast worker covered in thermal protection gear then starts to rotate a lever on the ladle which opens the gate at the bottom of the ladle to start the pouring of the 8630 alloy steel. After the pouring is complete, there is a 24 hour wait time for the steel to properly harden and cool down. When the 24 hour time period is up, the 8630 alloy steel is annealed in a process of getting a furnace up to 1600 °F and then placing the hammerhead in the oven for a total of 4 hours. When the time is up, the hammerhead is immediately water quenched to make the hammerhead soft for the purpose of machining faces, pockets and other features. This is done by taking the CATIA file of the part and making it into an STP file, then transferring it to Fusion 360 where the CMU team can use the software to program patterns to machine the

pockets, faces, chamfers, holes, and other features. After completion of the machining of the hammerhead, it is then sent back to Bay Cast where tempering is done by getting an oven to 1100 °F where the hammerhead is placed for a total of 8 hours. Once finished, it is set aside at room temperature to air cool which helps increase the strength and wear resistance properties of the 8630 alloy steel.

The hammerhead is then sent back to CMU where the team developed a handle that is ergonomic with an aesthetically pleasing design, while still resembling Viking style characteristics. At the top of the handle is an ellipse shape that has the same dimension as the hammerhead hole to give a snug fit to prevent any slipping. A small slit is then made at the top of the handle and a wooden wedge coated in wood glue, to help keep the wedge in place, is hammered into place to put pressure against the metal head to keep the handle from moving. To prevent the wooden wedge from slipping out, a metal wedge with bevels that grip the wood is hammered perpendicularly into the top of the handle and wooden wedge. From there, the CMU team stained the wood and added leather to give it an aesthetic look. From the step-by-step procedures, there needs to be data set in place for the team to complete Thor's Hammer by March 20th.

The timeline was organized starting from mid-January to March 20. Below is a detailed look at Central Michigan University's Thor's Hammer project timeline seen in Table #1.

Table #1: Project Timeline

Date	Description
January 14	Team Meeting #1: Discuss general details of the project with Dr. Lee, figure out preliminary individual roles.
January 17	Team Meeting #2: Finalize individual roles and tasks.
January 18	Team Meeting #3: Discuss possible questions for future Bay Cast visits.

	(What metals/alloys are available to use at Bay Cast? Aside from competition guidelines, what are Bay Cast's needs for the hammer design? Is the 6 pounds for just the head, or the entire hammer assembly?)
January 19	Team Meeting #4: Contact Michael Graebner of Bay Cast to schedule a plant visit.
January 20	Planned Bay Cast visit for January 26.
January 22	Team Meeting #5: Plan our visit and discuss more questions for the visit. (What is the plan for creating the mold? Discuss potential design concepts.)
January 26	Bay Cast Visit: Discussed project with Michael. Went over their casting and machining processes. Created concept ideas. Toured the facility.
January 27-31	Work on design concepts, potential materials/material list, and project memo. (ASTM 8630).
January 31	Team Meeting #6: Concept Scoring Matrix, pick designs to send to Bay Cast for their opinion.
February 1	Team Meeting #7: Finalize project memo.
February 2-3	Finalize CAD design of hammerhead and send to Bay Cast.
February 8	Team Meeting #8: Discuss midterm project presentation.
February 10-16	Work on midterm presentation.
February 17	Pattern Delivery.
February 23	Bay Cast Visit for Pattern Molding, Mold Pour and video recording.
February 24	Shakeout.
February 25	Anneal. Work on shaping hammer handle.
February 26	Castings arrive at CMU. Machine hammerheads (riser removal, chipping, grinding, CNC, and cleaning.) Assemble hammer and record test video.
March 2	Send hammerheads back to Bay Cast for quench and temper.
March 4	Hammer arrives back at CMU.
March 5-7	Shaping of the handle.
March 8	Final Assembly of the hammer.

March 9	Stain finish of the handle.
March 14	Leather applied to the handle.
March 19	Hammer shipped to Cast In Steel.

The first design concept seen in Figure #1 is a simple design with a rounded, tapered bottom for a unique shape with better support going into the handle.

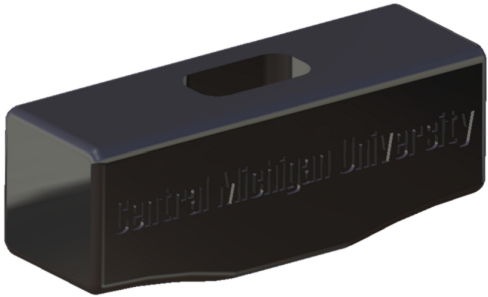

Figure #1

With this final iteration of the second design concept (Figure #2), the team used the idea of an exoskeleton as inspiration for the structural design. Two impact faces were connected using a hexagon shaft centered in the hammer, along with a vertical hexagon shaft used to run the handle through. Arched pockets were then cut out of all four long faces. Chamfers along all corners of the hammer were added to the design to make it resemble Thor's hammer, along with reducing mass. Fillets were also added between the two faces and the hexagon shaft for added support, and to reduce stress points.

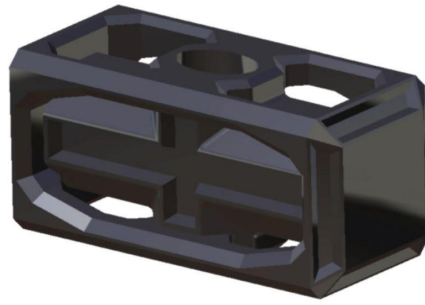

Figure #2

The third concept seen in Figure #3, the design focuses on the fictional Marvel character Thor's hammer. With its basic rectangular shape and chamfer design, it goes with the same look as Thor's Hammer.



Figure #3

The concept selection (Table #5) involved collecting the customer needs (Table #3) from the Cast in Steel competition, senior design capstone, and Bay Cast. Once the needs were formed through team discussions, they identified target specifications (Table #4) to meet each need with the most efficient design aspect. The specification table explains the needs that were met, the level of importance each specification has, its units and value. Lastly, the concept scoring matrix is used in combination with the needs and specifications to figure out which concept design will be the best on paper by rating each specification with its importance and totaling the numbers. The customer needs, target specifications, and concept scoring matrix can be seen below.

Given all the moving parts that would take place during this project in a condensed timeline, the organization and project management had to be a central priority. In the first week of receiving the project, our group started meeting virtually. After looking into the Cast in Steel guidelines, contacting Michael Graebner at Bay Cast, Dr. Ritter, and Dr. Lee, we were able to get a more clear picture of what was expected of our hammer and the project in general. Then we split up tasks/roles seen in Table #2.

Table #2: Individual Roles

Role	Primary	Secondary
Team Leader	Nathaniel Klebe	Darren Heath
Planner	Nathaniel Klebe	Carlie Root
CAD	Darren Heath/Trey Case	Michael Falco
MET	Nathaniel Klebe	Michael Falco/Carlie Root
FEA	Trey Case	Darren Heath
CNC	Darren Heath	Michael Falco
Casting	Darren Heath/Nathaniel Klebe	Michael Falco/Trey Case
Video	Michael Falco	Trey Case
Report	Shaheed al Jaffar/Carlie Root	Rest of Team
Shipping	Carlie Root	Shaheed al Jaffar
Aesthetics	Carlie Root	Shaheed al Jaffar

In a more detailed look at individual roles, as team leader and planner, Nathan Klebe kept the group organized and involved. He is responsible for making sure the group stays on task and on schedule to meet the needs of the project. Nate was also involved in helping with the CNC of the hammer. Darren Heath assisted Nathan with making sure the group knew what they were

doing and when. Darren was also in charge of the CNC programming and CAD design of the product. He also assisted in the FEA analysis of concepts and the final part. Trey Case was also in charge of CAD design and FEA analysis, as well as assisting in the video editing portion of the project. Michael Falco helped with CAD design, handle design, and was the primary video editor. Carlie Root assisted in the planning of the project. She was the primary asset in shipping and aesthetics. Shaheed Al Jaffar was a primary role in the report, along with assisting in shipping and aesthetics. All of the group members worked closely with Michael Graebner to learn and perform as much of the casting process as possible.

Table #3: Customer Needs/Guidelines

1.	The hammer is 6 pounds or less in weight.
2.	The hammer is 20 inches or less in length.
3.	The hammer completes tasks typical for “Viking Thor’s Hammer”.
4.	The hammer is created by using casting processes.
5.	The hammer possesses unique features.
6.	The shape resembles Thor’s Hammer.
7.	The handle is ergonomic.
8.	The weight is balanced proportionately.

Table #4: Specification Table

Spec #	Needs Met	Metric	Importance	Units	Value
1	1,8	Lightweight material and design	4	Lbs	n<=6
2	5	Replaceable parts	1	Count	n=>1

3	1,3,6,8	Reasonable and controllable head size	3	In	$n \leq 8 \times 5 \times 5$
4	4	Castable head design	4	Yes/No	Yes
5	2,7,8	Reasonable and controllable handle size	3	In	$1 < n < 2$ $6 < n < 14$
6	3	Strength of Hammer	4	Lbs	$n \leq 15,000$
7	5.6	Aesthetic of Hammer	2	Opinion	Thor/Viking

Table #5: Concept Scoring Matrix

Spec #	Imp.	Concept 1		Concept 2		Concept 3	
		Evaluation Score	Weight Score	Evaluation Score	Weight Score	Evaluation Score	Weight Score
One	4	5	20	5	20	4	16
Two	1	1	1	1	1	1	1
Three	3	5	15	5	15	4	12
Four	4	5	20	5	20	5	20
Five	3	4	12	5	15	5	15
Six	4	4	16	5	20	4	16
Seven	2	4	8	5	10	4	8
Total			92		101		88

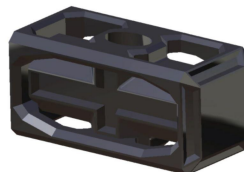
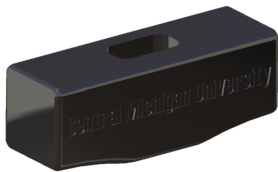

Based on the concept scoring and project stakeholders, the team decided concept two would be the main design, with either concept one or three being the backup. The main design accomplishes all the customer needs efficiently, it performed well in FEA testing, it has a unique and aesthetically pleasing look, all while resembling a viking Thor's hammer. The drawback of

the design picked would be the time to machine and create the finished product compared to the other concepts. Thankfully, Bay Cast would accept multiple designs to cast so we sent the main concept along with concept one as a backup in case the deadlines caught up to the group.

After finalizing the head design, other materials and the project costs had to be determined. The hammerhead is made of ASTM A958 SC 8630 Class 90/60 steel for its impressive strength. The CMU team is grateful for the cost of casting and other materials to be covered by our sponsor, Bay Cast. The handle was to be handmade out of three blanks of Ashwood totaling \$24.70. Ashwood has an impressive hardness of 1200. It also possesses properties of shock absorption while being lightweight. Wood shims and steel wedges were needed for the handle assembly at \$3.00. 40-400 grit sandpaper was needed for the handle as well at \$12.99. A coping saw was needed for cutting intricate shapes in our handle at \$8.98. Wolman RainCoat Clear oil-base exterior wood sealer at \$23.98. Leather for the handle at \$15. Titebond II premium wood glue for a fast-setting, yet strong bond at \$2.79. Araldite Heavy Duty Epoxy Adhesive at \$11.48. The material cost outside of casting and the steel came to \$107.92.

Assembling the hammer went smoothly due to the calculation between the CAD designing and the machining and the hammer handle, resulting in the hammer handle being a tight fit in the hammerhead by adding the wood and the metal wedges, plus the leather to cover the handle to give it a Viking look. The wood handle design gives the hammer an ergonomic feel and the look of Thor's Hammer.

Manufacturing more hammers with similar aspects to the hammer the group made might be challenging to other people, the design of the hammer is a little more complex than regular hammers, the CAD designing took a long time to make using different designing apps starting with CATIA and then transferred to Fusion 360 just to make the mold by Baycast. Then the

melted metal was poured into the mold to get the raw rough shape of the hammer, after that, it was transformed from a shape to code that can be inserted into the CNC machine at CMU, while the CNC is running, using Ashwood blank to make the handle to the desired shape by hand. In conclusion, the hammer can be manufactured but only with the hammerhead CAD sketch and the mold to pour the metal.

One thing the team noticed that would have helped speed up the process was making a homemade mold through CMU's shop, hence Bay Cast only works with large parts casting, making smaller molds for smaller parts might not be their kind of work. Making a smaller mold in the CMU shop and focusing more on that would have sped up the design process as well as made more accurate casting for the hammerhead.

Chapter 4. Engineering Design and Analysis

The final head design performed well in FEA testing. The group conducted static case CATIA FEA tests with an applied force of 1600 N to the hammering face of the head while restraining the opposite face with the clamp tool. The tests ran with the material properties of 8630 low-alloy steel for the most accurate results possible. Vibration, force, stress, and displacement data were all collected.

The mold consisted of the 3D negative design of the main hammerhead, along with a more simple backup head design. The cope of the mold consisted of four risers with the main feeder riser (sprue) in the center where the molten metal would be poured into seen in Figure #4. Since the hammerhead designs were evenly spread out in the pattern, a center positioned sprue would evenly pour and spread the metal into the entire mold. Four risers help prevent unwanted cavities in the final part when the metal cools.



Figure #4

The FEA testing of the hammerhead began with a tetrahedron mesh size of 0.10 inches with an absolute sag of 0.01 inches of the part. A clamp restraint was placed on one of the faces of the hammerhead, while a distributed force of 1600 N was placed on the opposite striking face. The static case solution data showed the Von Mises stress in Figure #5 with a maximum of $3.66476 \times 10^6 \text{ Nm}^2$ and a minimum of $32,016 \text{ Nm}^2$. The translational displacement, seen in Figure #6, maximum was 4.05315×10^{-5} inches and a minimum of 0 inches. The amplification magnitude was placed at 10,000 so the deformation of the hammerhead would be easier to view. The stresses are spread evenly, with no sharp rises in certain areas.

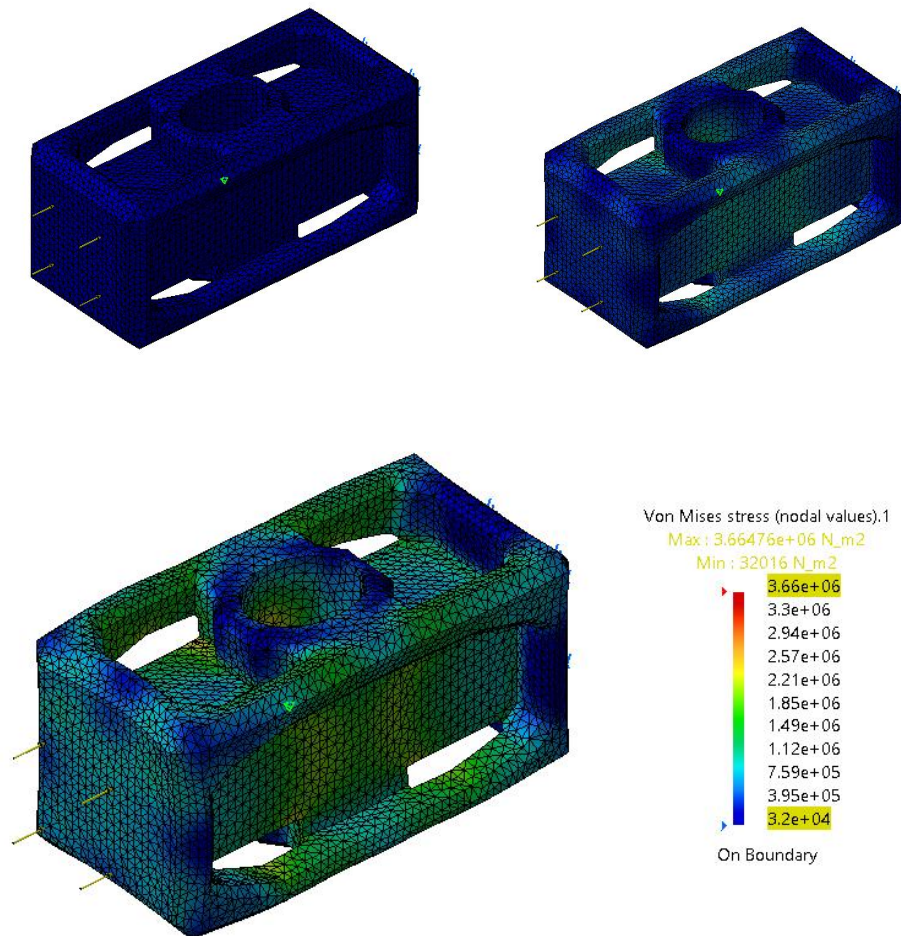

Figure #5

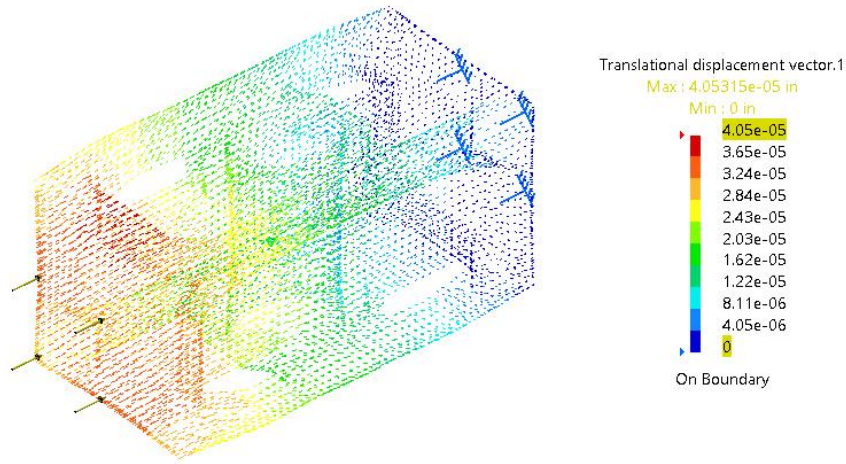

Figure #6

The vibration analysis seen in Figure #7 used the same clamp on the end face of the hammerhead. In calculating the frequency analysis case solution, the frequency was 1788.63 Hz. The Von Mises stress maximum was $1.87891e+12 \text{ Nm}^2$ and minimum $4.47929e+09 \text{ Nm}^2$. If there were any unwanted gaps between the handle and the hammerhead, the vibration would cause irritation when hammering, as well as weaken the integrity of the hammer as a whole.

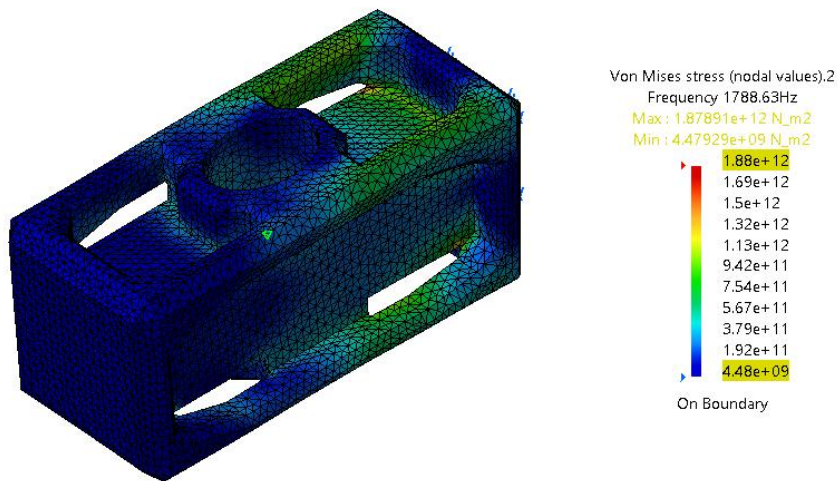

Figure #7

From the FEA testing, the design of the overall hammer worked tremendously when dealt with high forces and high vibrations. Having the pockets and the chamfers included in the design without disrupting the core of the alloy steel keeps the hammer solid which helps keep the strength of the steel. When it then came to having the hammer cast and machined, in order to make sure the hammer was casted properly a physical test was then organized and performed to check the strength of the 8630 alloy steel.

To test the hammer in person, the group created a test video experiment to measure the force exerted by the hammer. Nails were measured after being struck by a 15.2 lb metal block dropped from 15 inches to gather a baseline of data. After multiple tests and using the speed, distance, and weight the force of the block could be calculated. The average force of the block was compared to the weight and distance of Thor's Hammer and the nail in the main test. The force of the hammer came out to 1,288 N.

Chapter 5. Conclusion

Throughout the group's experience of producing and manufacturing this hammer, a number of problems arose. For starters, the team focused more on the design aspect of the hammer, rather than the manufacturability of the project. The team was so focused on creating a conceptually pleasing and superior design that they did not account for the amount of difficulties they would run into, which included, but were not limited to: the difficulty of creating a pattern with such a complex design, using foam to create the mold rather than machining a pattern and mold in-house for ease of the molding process, not ordering the tools that the team needed for our CNC to cut steel at a faster rate. A majority of the issues were because of time constraints that the team faced. Having waited so long to start the casting process and order the tools caused major time constraints and a lot of stress on the team to cram in so much work in so little time.

Overall, our project turned out to be quite successful. The team was very pleased with how the final hammer turned out. Unfortunately, there was some porosity with the cast, but it was quite minimal. The porosity actually gives the hammer a unique look that feels very rustic and old, while still maintaining structural rigidity and exceptional properties. The handle was hand carved and turned out spectacular, also with exceptional strength properties. CMU's sponsor, Bay Cast, did an exceptional job with the time they were given. They were also very pleased with the completed hammer.

Even though the hammer turned out incredible, there are always areas of improvement that could be had. Areas that the team could improve upon would be starting on the casting process immediately to reduce the amount of porosity that the cast ended up with. Planning ahead is the biggest improvement, time management is a huge aspect of a project with multiple moving parts. If the team had thought about how difficult the part was going to be while being

machined or how long the part was going to take to be machined they would have ordered the tools needed sooner and came up with a design that wasn't as complex to reduce the amount of machining time/difficulty and reduce the amount of time to produce the patterns the team needed to cast the hammer.

References:

1. Bussolesi, M., Grieco, G., Eslami, A., & Cavallo, A. (2020). Ophiolite chromite deposits as a new source for the production of Refractory chromite sands. *Sustainability*, 12(17), 7096. <https://doi.org/10.3390/su12177096>
2. Glowina, J. (2017). *Metallurgy and Technology of steel castings*. Bentham eBooks.
3. International, A. S. M. (2009). *Casting design and performance*. ASM International.
4. How do you get to VIKING VALHALLA? (2020, September 15). Retrieved February 23, 2021, <https://www.bbc.co.uk/teach/how-do-you-get-to-viking-valhalla/z7s747h>
5. Galles, D. J., & Beckermann, C. (2017). Prediction of distortions and pattern allowances in steel sand castings. *Prediction of Distortions and Pattern Allowances during Sand Casting of a Steel Bracket*, 30(NO.3). <https://doi.org/10.17077/etd.1vr08qwp>
6. Wang, J., Sama, S. R., & Manogharan, G. (2018). Re-Thinking Design Methodology for Castings: 3D Sand-Printing and Topology Optimization. *International Journal of Metalcasting*, 13(1), 2–17. <https://doi.org/10.1007/s40962-018-0229-0>
7. Hoyt, D. (2006, February 1). *Mining a domestic source OF Chromite: A mineral deposit in Oregon is being developed to be a significant source of CHROMITE sand for U.s. metalcasting Facilities, offering a cost-effective alternative to the current South african CHROMITE CHOICES*. <https://www.thefreelibrary.com/Mining+a+domestic+source+of+chromite%3a+a+mineral+deposit+in+Oregon+is...-a0142573105>.

8. GREEN, D. (2018). Coreless Induction Furnaces and Metal Bath. *Modern Casting*, 108(11), 48–52.

9. International ASTM, *Customize your engineering360 experience*. (2013, January 4). <https://standards.globalspec.com/std/10156785/ASTM%20A958/A958M>.

10. *Steel Grading: Chemistry and Properties*. Reliance Foundry Co. Ltd. (2021, March 4). <https://www.reliance-foundry.com/blog/steel-grades>.

Appendix:

Appendix A. Detailed Engineering Drawing of Part

Thors Concept

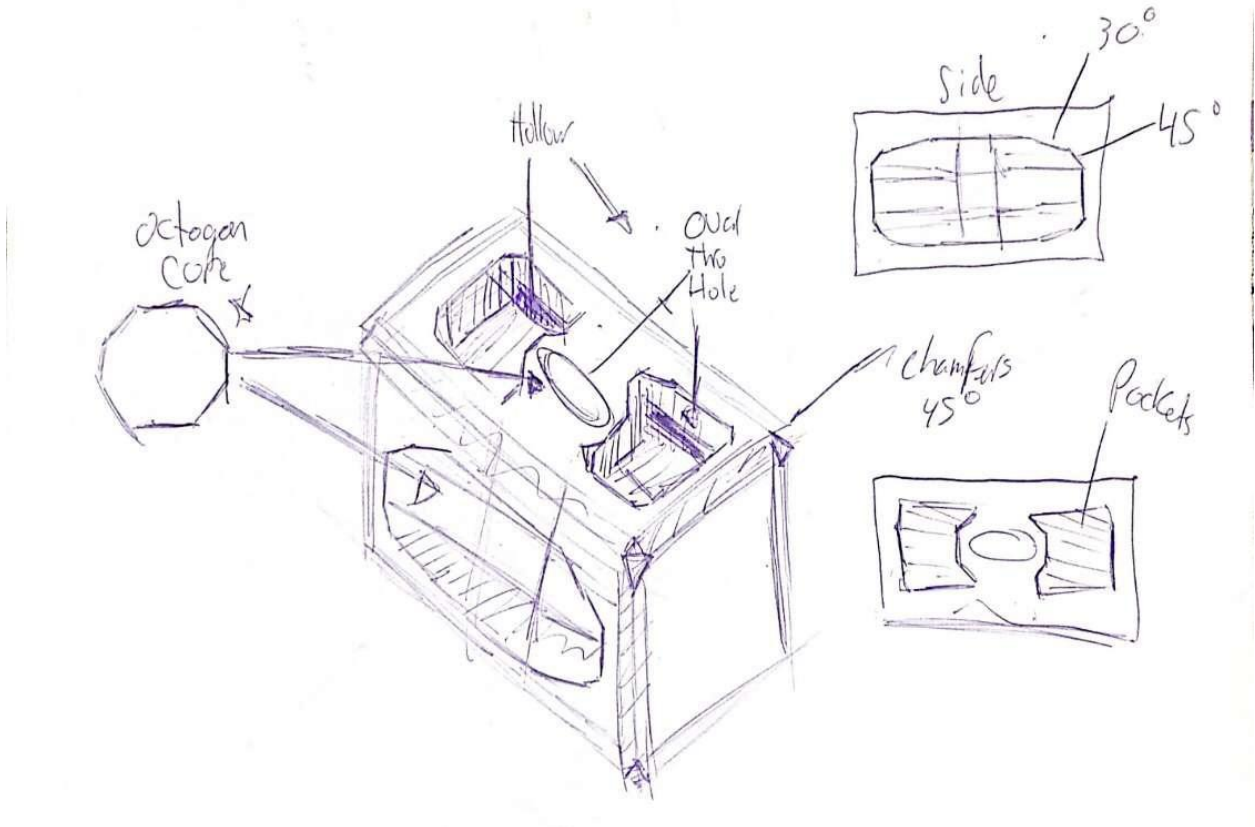

Appendix B. Rendering of Final Design



Appendix C. Bill of Materials

Material List

- ASTM A958 SC 8630 Class 90/60
- Ashwood, Three 2" X 2" x 16" blanks
- Wood shim
- Steel wedge
- Wolman Raincoat clear oil-base exterior wood sealer
- Leather
- Titebond II premium Wood Glue
- Araldite Heavy duty epoxy adhesive
- Sandpaper
- Coping Saw
- Packing Foam
- Wood Stain
- Styrofoam hammer pattern
- Dremel Bits
- CNC steel drill, end mill, 45 chamfer mill

Appendix D. Final Cost Model

<u>Material</u>	<u>Cost</u>
<u>ASTM A958 SC 8630 Class 90/60</u>	<u>Covered by Bay Cast</u>
<u>Ash Wood</u>	<u>\$24.70</u>
<u>Wood Shims/ Steel wedge</u>	<u>\$3.00</u>
<u>Wood sealer</u>	<u>\$23.98</u>
<u>Leather</u>	<u>\$15.00</u>
<u>Wood Glue</u>	<u>\$2.79</u>
<u>Epoxy Adhesive</u>	<u>\$11.48</u>
<u>Sandpaper</u>	<u>\$12.99</u>
<u>Wood Stain</u>	<u>\$10.00</u>
<u>Coping Saw</u>	<u>\$8.98</u>
<u>Packing Foam</u>	<u>\$30.00</u>
<u>Hammer Pattern</u>	<u>Covered by Bay Cast</u>
<u>Casting Mold</u>	<u>Covered by Bay Cast</u>
<u>Dremel Bits</u>	<u>\$15.00</u>
<u>Total</u>	<u>\$157.92</u>

Appendix E. Project Photo Album

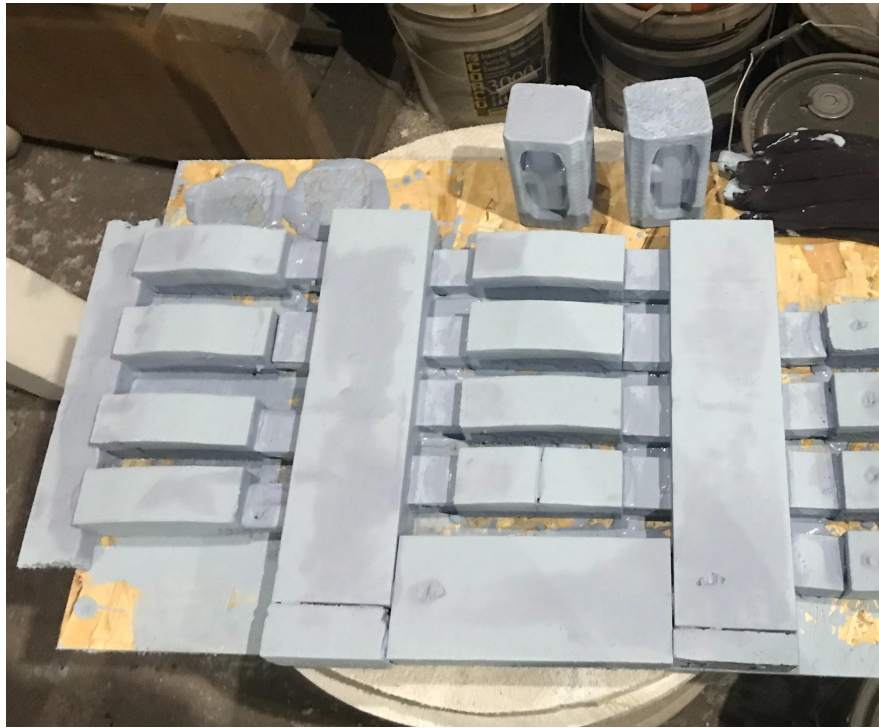

- This is the styrofoam pattern for constructing the mold for the casting process.



- This happens during the creation of the mold, using the pattern to create the shape of the hammerhead.



- This is a hammerhead after the casting process was complete, before any machining.



- The final product, after the casting and machining process, and attachment of the handle. (Before the second coat of stain: top photo... After: bottom photo)





- Candid photographs of the final hammer assembly



- Central Michigan University (CMU) Team, from left to right; Darren Heath, Nate Klebe, Carlie Root, Shaheed al Jaffar, Trey Case, Mike Falco