

# Cast In Steel Thor's Hammer

ENSAM Cluny

Cécile Nicoli, Clément Dos Santos, Morgan Souêtre

## Table des matières

Team .....	3
Design .....	3
History .....	3
Head .....	3
Handle .....	3
Risers and coolers.....	4
Alloy .....	5
Manufacturing process.....	6
3D Printing.....	6
Sand casting.....	6
Fusion and casting .....	7
.....	9
Shakeout.....	10
Finishing.....	11
Acknowledgements .....	12
SAFE Metal group .....	12
ENSAM Cluny.....	12
ECAM Lyon.....	12

## Team

Cécile Nicoli PhD, research engineer at SAFE Metal group

Clément Dos Santos engineering student at ENSAM Cluny

Morgan Souêtre PhD Student at ENSAM Cluny in contract with SAFE Metal group

## Design

### History

In the north mythology, Thors's hammer is called Mjolnir. This hammer as a short handle and a heavy head due to the malicious action of Locki the prankster god. Create from steel by dwarf, Mjolnir is the most powerfull weapon but also a fabulous creation tools. Thrown, it return systematically to the thrower, but only worthy people can handle it.

### Head

Different design are used in the ages. Massive and cubic or slender and sculpted, different design are used as we can see in Figure 1.

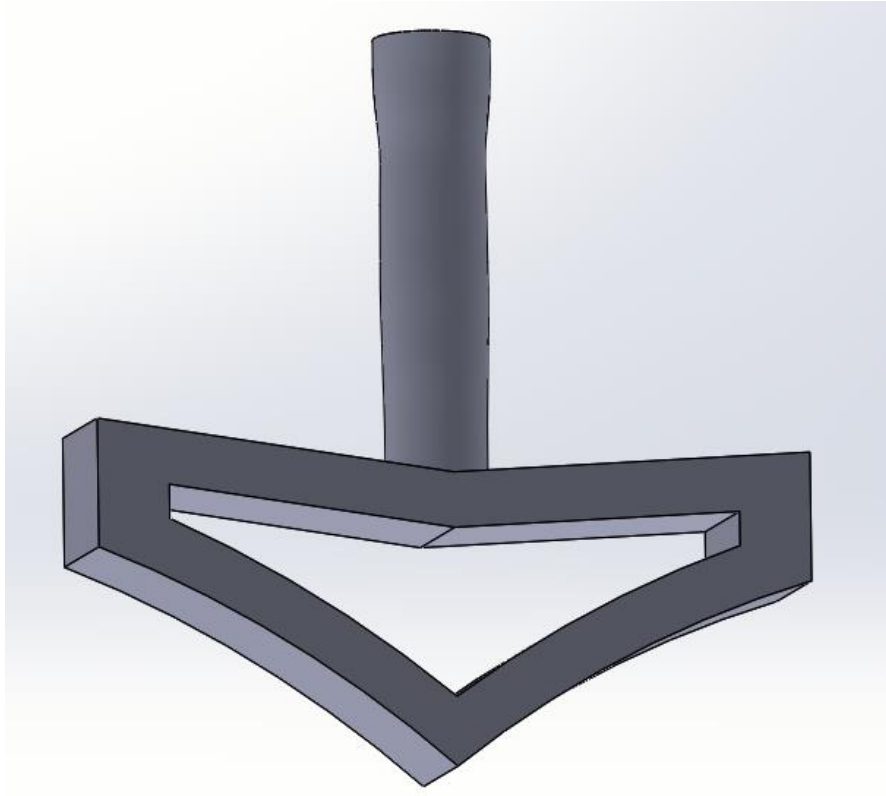

*Figure 1 Thor's hammer different designs*

Our design is choose due to the weight constraint and the will to achieve the handle and the head as an unique part in steel as the dwarf does.

### Handle

The handle, made in the same cast as the head, is shape to offer a good gripping, but above all to allow a high powerful strike and a good balance to be thrown. The main objective to this handle is to be cast and operational right out of the mold. Another interest of this design is to use it as riser, and it should be shorter due to the shrinkage of the steel.



*Figure 2 Hammer design*

The choice to put the head down complicates the task for molding. Ideally, the designer prefer to use an easiest joint surface. But for symmetry, soundness and for the handle realization we choose to use a core for the center. This orientation, choose when a fly bites the designer, gives us also a shorter handle due to the shrinkage.

#### Risers and coolers

To get a clean and harder surface due to oriented solidification, we choose to use cooler (in green) in contact with the hammer knocker. These cooler in combination with a riser, give us a sound casting.

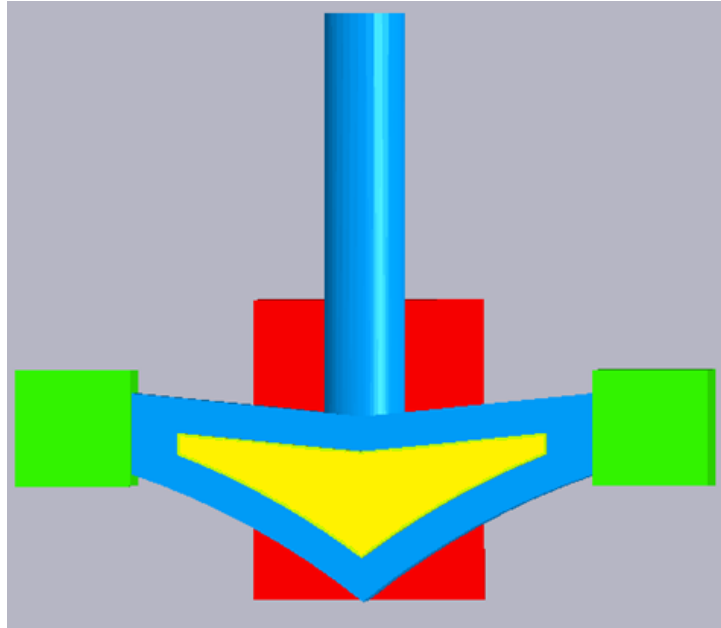

Figure 3 Hammer with core, chills and riser

This riser, in red, oversized by the designer. He was bites by this terrible fly and lost control. This size cause the riser sucks the metal out of the handle and shortcut it. We choose to fill directly through this riser to get smooth filling and avoid mold degradations.

## Alloy

The alloys selected are AISI 1045 and AISI 1075. This alloy commonly used for hardened tools and easy to make with the original steel grade we have. We need to add 0.1% C and 0.4% of chrome for 1045 and 0.45% C for the 1075. These grades could be hardened thanks to a quenching in water with clay protections. Unfortunately, due to the pandemic, we only could do one session of casting and we do not had time for quenching.

In the table below, we note the compositions of alloys. The compositions where measured at SAFE Metal, thanks to a spark spectrometer.

Grade	C	Si	Mn	Ni	Cr
Our nuance	0.3%	0.37%	0.8%	0%	0%
1045	0.45-0.5%	0.4% max	0.5-0.8%	0.4% max	0.4% max
1075	0.73-0.78%	0.1-0.3%	0.-0.8%	0.2% max	0.15% max
Adding 1	0.18%	0	0	0	0.4%
Adding 2	0.45%	0	0	0	0
Grade 1	0.32%	0.43%	0.84%	0.03	0.41%
Grade 2	0.43%	0.37%	0.83%	0.03	0.08%

Due to use of a 2 liters silicon-carbide crucible, we have a variation on our composition and an efficiency of our adding non controlled. The graphite added to the melt as an efficiency of 1/3 and the FeCr add a very high concentration of chrome. The deoxydation was done with aluminum at 0.15%.

## Manufacturing process

### 3D Printing

Every models are 3D printed; ideally, we would have machined it in wood, to use it in press casting. However, 3D printing give us a quicker result and due to the manual casting, with an epoxy coating it resist to the crusher tool. This coating give us a smooth surface, essential for molding.

### Sand casting

Our casting are handmade, that's generate defects, but, as Brokk and Eitri, we use the power of our arm to realize the bests tools. The molding material is a silica sand with 9% of bentonite and 4% of water.



*Figure 4 Sand molding down part*

The cast is divided in two part: down part with the head, the riser, the chills and the core and the upper part with the handle.



*Figure 5 Sand molding upper part*

The core made with furane sand is inserted after model removing.

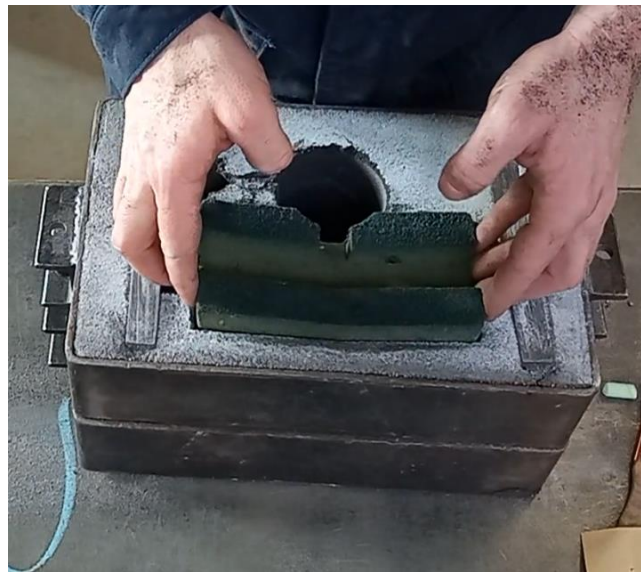

*Figure 6 Core insertion*

### Fusion and casting

The fusion was made in a crucible induction furnace. We fuse 15kg of metal each time and this permit to fill two molds. After melting we add graphite and Fe-Cr. When there are mixed we add aluminium and take measure to reach 1650°C.





*Figure 7 Melt température mesurement*

Before casting, we need to clean the melt, because oxides float on it. Due to this operation and low volume of the crucible, the melt lose temperature very quick.





*Figure 8 Melt cleaning*

After cleaning the technician cast the part, the metal is around 1600°C and 1550°C.



*Figure 9 Casting*

### Shakeout

At the shakeout the sand adhere to the metal and form a hard glass layer. This will be remove with sandblasting. After this, we cut the riser, easy operation thanks to the design, and we cut the shrink part of the handle.



*Figure 10 Shakeout*

We finish with a simple sanding to get a good surface.

The sand casting give to the handle a good grip to throw or hit.

## Finishing

Due to the pandemic and the lack of time with lock down and restrictions, the hammer is not finished. The quenching wasn't done and the finishing isn't really good. Despite that this was a great adventure and we had three other hammer to finish.



## Acknowledgements

### SAFE Metal group

SAFE metal, our industrial, supported us in this project. They provide us the steel and some advices. This steel founders company with different sites in the world and is part of the SFSA with is site of Mexico.



L'esprit industriel

### ENSAM Cluny

ENSAM Cluny is our university and casting site and the university where we realize the casting. We thank Patrice Honoré, the foundry technician, for his help and his professionalism.



### ECAM Lyon

Philippe Jacquet and Alexis Vaucheret was the professor that support us in this project. They work in ECAM Lyon and give us good advices.

